

# 496 系列油雾器 series Oil atomizer



## 图形符号 Graphical symbols



## 型号注释 Note for type

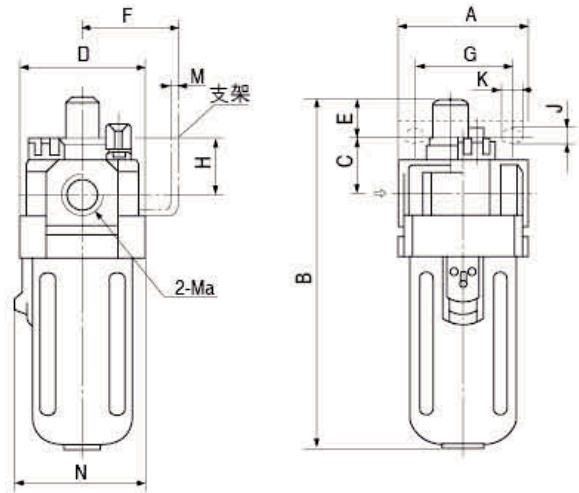
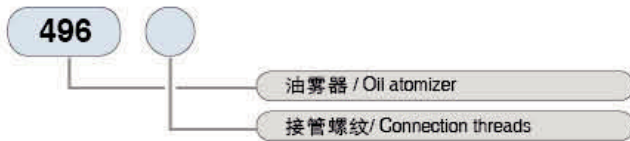

## 外形尺寸 Outlook & Dimension

型号 type	Ma	A	B	C	D	E	F	G	H	J	K	M
496.11	M5	25	71	7	25	-	-	-	-	-	-	-
496	G1/8 G1/4	40 / 48	128	11	40	17	30	27	22	5.4	8.4	2
496	G3/8 G1/2	70 / 78	173	18	70	17	50	54	26	8.5	10.5	3
496	G3/4 G1	95 / 107	274	24	95	23	70	66	35	11	11	3

## 技术参数 Specification

最大工作压力/Max working Pressure	1.0MPa
工作温度 / Working tempt	5 ~ 60°C

### 流量 / Flow rate

m<sup>3</sup>/h (L/min)

接管螺纹 Connection threads	G1/8 ~ G1/4	G3/8 ~ G1/2	G3/4 ~ G1
通径 passage dia (mm)	6 ~ 8	10 ~ 15	20 ~ 25
输入压力 P1 Pressure input P1 (MPa)	Min: 10滴/分时的最小流量; Max: 当△P=0.1MPa时最大流量 Min: At 10 drops/min minimum flow rate; Max: when pressure drop △P=0.1MPa, Max flow rate Min / Max		
0.1	2.5/20 (40/330)	1.5/80 (25/1330)	8.5/210 (140/3500)
0.25	3.5/35 (60/580)	2.5/120 (40/2000)	9.2/240 (150/4000)
0.4	4/50 (65/830)	3/170 (50/2830)	10/265 (165/4415)
0.6	5/60 (80/1000)	4/220 (65/3665)	11/295 (180/4920)
0.8	7/80 (115/1330)	6/290 (100/4830)	13/350 (215/5830)
1.0	10/105 (165/1750)	9/360 (150/6000)	16/450 (265/7500)

# 油雾器的配接管直径小一号时, 最大流量约减少10%。  
# With pipeline to the atomizer one size smaller in diameter, max flow rate reduces by approx 10%.