

# Q23XD 系列二位三通电磁先导阀

## Series 3/2-ways pilot Solenoid Valves



### 图形符号 Graphical symbols



### 产品特点 Features

Q23XD型二位三通先导电磁阀分常闭、常通两种型式。电磁阀接受电信号以切换气路。由于该阀的公称通径是 2 mm，流量较小，所以常用作换向阀的先导阀，或在气动系统中作为切换元件(较小流量情况下)。电磁阀具有体积小，动作可靠换向灵敏等特点。

K23D 3/2-ways pilot solenoid valves are divided into two types normal open and normal close solenoid valve receives electrical signals and switches air directions. As this valve has a nominal passage dia of 2mm and has small flow rate it is usually used as the pilot valve for the directional valve or as the switch element in pneumatic systems (Where flow rate is small). This solenoid features compactness, reliable action and sensitivity in directional change.

### 型号注释 Note for type

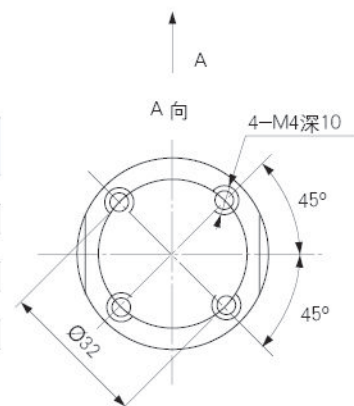
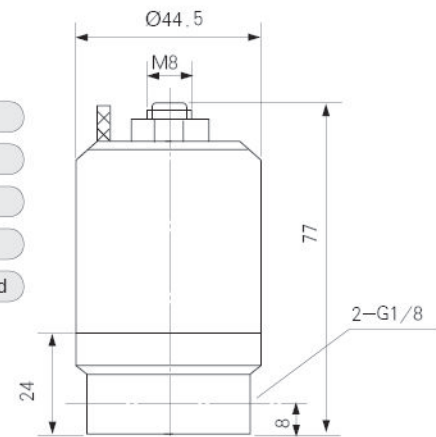

### 技术参数 Specification

型号 Type	Q23XD-2	Q23XD-2T
参数 Item		
工作介质 Working medium	洁净的压缩空气 Cleaned compress air	
工作压力 Working pressure(MPa)	0~0.8	
有效截面积S值 Effective sectional area svalue(mm <sup>2</sup> )	≥2	
最高切换频率 Max switch over frequency(Hz)	≥15	
工作寿命(万次) Working life(10K times)	200	
工作电压 Voltage(V)	AC:380,220,110,36, DC:220,110,24	